

# Stellar and Planetary Aberration

Thomas E. Phipps, Jr.  
908 South Busey Avenue  
Urbana, Illinois 61801

*A way of looking at the topics of stellar and planetary aberration is suggested that enables them to be viewed as closely related—both being conceived as dependent on source-detector relative velocity. We show that the long-range limiting case, stellar aberration, has certain uniquely subtle aspects, as well as some hypothesized characteristics that lend themselves to empirical testing.*

## Introduction

For some time the writer has been seeking improved understanding of the several kinds of aberration—these being rather superficially explained in most texts, particularly texts of relativity theory. Indeed, in some of the more highly regarded of these (e.g., Møller 1972) the phenomenon of stellar aberration is so slightly treated that use of the formulas provided would literally yield wrong answers. During much of this investigation it seemed that the fault lay with special relativity theory or with the Lorentz transformation. This may still, or may not, be the case. The reader will have to judge. Interest particularly in stellar aberration has increased of late [cf., Ives 1950, Eisner 1967, Phipps 1989, Hayden 1993, etc.] With help from recent studies by Marmet (1994) and Sherwin (1993) it has become apparent to the writer that *with suitable interpretation* relativity theory can accommodate both principal types of optical aberration, planetary and stellar. The purpose of the present paper is to confirm this assertion, to exhibit stellar aberration as (in a sense) a limiting case of planetary aberration, to seek a physical model of the phenomenon, to describe observations that could be made to test the model, and to touch on residual aberration issues that remain unsettled in the context of relativity theory.

## 1. Aberration via Lorentz Transformation

First, let us deal with the mathematics—which is the easy part—so that we can get on to the real problem, which (as so often happens in physics) is interpretation. According to the special theory of relativity (Einstein 1905) both the Doppler effect and stellar aberration can be treated by a Lorentz transformation of the four-vector of light propagation,

$$k_m = \left[ k_x, k_y, k_z, \frac{i\omega}{c} \right], \quad k = \sqrt{k_x^2 + k_y^2 + k_z^2} = \frac{\omega}{c}.$$

Inertial system K' moves with velocity  $\mathbf{v}$  relatively to sys-

tem K along the direction of their common  $x$ -axes. We consider both K and K' to be for the moment arbitrary inertial systems. Propagation vectors (wave-normal or ray-path vectors) describing the same given light beam are  $\mathbf{k}'$  and  $\mathbf{k}$  in K' and K, respectively. Applying a Lorentz transformation, we have

$$k'_x = g \left[ k_x + \frac{v}{ic} \frac{i\omega}{c} \right], \quad g = 1/\sqrt{1 - (v/c)^2}$$

$$k'_y = k_y, \quad k'_z = k_z,$$

$$\frac{i\omega'}{c} = g \left[ \frac{i\omega}{c} + \frac{iv}{c} k_x \right], \quad \text{or } \omega' = g(\omega + vk_x).$$

From this it is verifiable that a directional turning of the  $\mathbf{k}$ -vector,  $\mathbf{k}'/k' \neq \mathbf{k}/k$ , is an unavoidable consequence of the Lorentz transformation, except in the special case of parallelism of the  $\mathbf{v}$ - and  $\mathbf{k}$ -vectors.

To specialize for simplicity to a specific model, let the  $x$ -direction (parallel to earth's orbital motion), in our "laboratory" (observatory) system K, lie in the horizontal plane of the ecliptic; let the  $z$ -axis lie in the vertical, defining the zenith direction; and (to eliminate diurnal effects) consider our telescope to be located at the north pole of a nonrotating earth, so that the pole of the ecliptic lies at the zenith. To treat stellar aberration, consider a star emitting light described by the  $\mathbf{k}$ -vector to lie in the  $x$ - $z$  plane at angle  $\alpha$  measured from the horizontal. Then  $k_x = k \cos \alpha = (\omega/c) \cos \alpha$ . In K' the corresponding angle  $\alpha'$  obeys  $k'_x = (\omega'/c) \cos \alpha'$ . With these substitutions it follows from the first of the above Lorentz transformation equations that  $(\omega/\omega') \cos \alpha' = g [\cos \alpha + (v/c)]$  and from the last of them that  $\omega'/\omega = g [1 + (v/c) \cos \alpha]$ . On taking the quotient of these equations we obtain the well-known relation (Synge 1965)

$$\cos a' = \frac{\cos a + \frac{v}{c}}{1 + \frac{v}{c} \cos a}, \quad (1a)$$

or its dual (symmetric with respect to interchange of K, K', with sign change of relative velocity),

$$\cos a = \frac{\cos a' - \frac{v}{c}}{1 - \frac{v}{c} \cos a'}. \quad (1b)$$

Subtracting  $\cos a$  from both sides of (1a), using a standard trigonometric identity (Peirce 1957), and introducing an aberration angle  $e = a - a'$ , we obtain

$$2 \sin \frac{e}{2} \cdot \sin \left[ \frac{a}{2} - \frac{e}{2} \right] = \frac{b \sin^2 a}{1 + b \cos a}, \quad (2)$$

where  $b = v/c$ . Observing that  $e = O(b)$ , we can expand the left-hand side of (2) as a power series in  $e$ ,

$$LHS = e \sin a - \frac{\cos a}{2} e^2 - \frac{\sin a}{6} e^3 + O(b^4).$$

Substituting  $e = ab + bb^2 + cb^3 + O(b^4)$ , where  $a, b, c$  are unknown coefficients, and equating the resulting  $b$ -power series to the series expansion of the right-hand side of (2) in powers of  $b$ ,

$$RHS = b \sin^2 a - b^2 \cos a \sin^2 a + b^3 \sin^2 a \cos^2 a + O(b^4),$$

we obtain, upon equating coefficients of successive powers of  $b$ , a sequence of equations that determine  $a, b, c$ , with the result (including the fourth-order term) that

$$e = b \sin a - b^2 \frac{1}{2} \sin a \cos a + b^3 \frac{1}{6} \sin a (1 + 2 \cos^2 a) - b^4 \frac{1}{8} \sin a \cos a (1 + 2 \cos^2 a) + O(b^5) \quad (3a)$$

or 
$$e = \frac{v}{c} \sin a + O\left(\frac{v^2}{c^2}\right). \quad (3b)$$

The first-order term here [which verifies  $e = O(b)$ ] is the one usually given, and is the only order accessible to observation with present-day telescopes. We show some of the higher-order terms because they are seldom derived and not always consistently represented (e.g., Aharoni 1965 shows an apparent  $g$ -dependence). The dualism prescription,  $a \leftrightarrow a'$ ,  $b \rightarrow -b$ , with  $e \rightarrow -e$ , works with the expansion, as with (1).

The above calculation loosely follows Einstein (1905), who made the interpretation that K' is the rest system of the *light source* and claimed thereby to describe stellar aberration. It is interesting to note that the above formal ma-

nipulations apply to *arbitrary inertial systems*. But, if one wants the formalism to relate to physics, close attention must be paid to physical interpretation. Einstein's 1905 interpretation, implying  $v = v_{sd}$ , where  $v_{sd}$  is the source-detector relative velocity (rather, a transverse component of it), applies formally to *planetary* aberration. It is incorrect (i.e., gives the wrong numerical answer) if directly applied to *stellar* aberration—as has been pointed out by Eisner (1967) and by Hayden (1993). The error was noted by Ives (1950) in connection with spectroscopic binary evidence and later by Phipps (1989) on related evidence. It is trivially obvious, inasmuch as any dependence of stellar aberration angle on  $v_{sd}$  would imply dependence on stellar (source) velocities—which vary so tremendously as to render description of the phenomenon by means of a single “constant of aberration” entirely unfeasible. Nevertheless, and somewhat paradoxically, we shall presently show that *by suitable interpretation* stellar aberration can be viewed as a limiting case of planetary aberration.

## 2. Aberration via Velocity Composition

To finish with formal preliminaries we consider an alternative relativistic description of aberration using the general velocity composition law of special relativity theory. Again we consider arbitrary inertial systems K, K' with light propagation vectors  $\mathbf{k}, \mathbf{k}'$ , respectively, and with  $\mathbf{v}$  the velocity of K' with respect to K. This time, however, we introduce photon velocity vectors  $\mathbf{u} = c\mathbf{k}/k = c\hat{\mathbf{n}}$  and  $\mathbf{u}' = c\mathbf{k}'/k' = c\hat{\mathbf{n}'}$ , where  $\hat{\mathbf{n}}, \hat{\mathbf{n}'}$  are unit vectors in the direction of propagation of a given light ray (“trajectories” of a given photon in the two systems, for a particle model of light). Møller (1972: Equation 2.55, page 51) gives the general velocity composition formula

$$\mathbf{u}' = \frac{\sqrt{1 - v^2/c^2} \mathbf{u} + \left[ \left\{ 1 - \sqrt{1 - v^2/c^2} \right\} (\mathbf{u} \cdot \mathbf{v}) / v^2 - 1 \right] \mathbf{v}}{1 - (\mathbf{u} \cdot \mathbf{v}) / c^2}.$$

Introducing into this formula by  $\mathbf{v} = c b \hat{\mathbf{m}}$  the unit vector  $\hat{\mathbf{m}}$  in the direction of  $\mathbf{v}$ , substituting for  $\mathbf{u}, \mathbf{u}'$ , and taking the scalar product of the resulting equation with  $\hat{\mathbf{n}}$ , we find

$$\hat{\mathbf{n}}' \cdot \hat{\mathbf{n}} = \frac{\sqrt{1 - b^2} + \left[ \left\{ 1 - \sqrt{1 - b^2} \right\} (\hat{\mathbf{n}} \cdot \hat{\mathbf{m}}) - b \right] (\hat{\mathbf{n}} \cdot \hat{\mathbf{m}})}{1 - b (\hat{\mathbf{n}} \cdot \hat{\mathbf{m}})}. \quad (4)$$

Employing the angles  $a, a'$  previously introduced and the “aberration angle” or angle between the photon trajectories in the two systems as the difference  $e = a - a'$ , and noting that  $(\hat{\mathbf{n}}' \cdot \hat{\mathbf{n}}) = \cos e$ ,  $(\hat{\mathbf{n}} \cdot \hat{\mathbf{m}}) = -\cos a$ , we obtain

$$\cos e = \frac{\sqrt{1 - b^2} + \left[ \left\{ 1 - \sqrt{1 - b^2} \right\} \cos^2 a + b \cos a \right]}{1 + b \cos a}. \quad (5)$$

This can be shown by standard trigonometric identities to agree with Equation (1) and thus with the expansion (3).

Alternatively, we can obtain the expansion directly from (5) by representing  $\mathbf{e}$ , as before, as a power series in  $\mathbf{b}$  with undetermined coefficients, expanding the left-hand side of (5) as a Taylor series in  $\mathbf{b}$ , equating this to the right-hand side similarly expanded, and evaluating the undetermined coefficients to yield the same result as previously obtained, Equation (3a). Thus the two methods, (a) photon velocity composition and (b) Lorentz transformation of the propagation vectors, yield identical results for aberration.

For describing stellar aberration both methods are wrong if  $\mathbf{b}$  is interpreted as  $v_{sd}/c$ , where  $v_{sd}$  is source-detector relative velocity. Both are right if  $\mathbf{b}$  is interpreted as  $v_{orb}/c$ , where  $v_{orb}$  is orbital velocity of the earth in the case of terrestrial observations, or if  $c\mathbf{b}$  is interpreted more generally as the component transverse to line of sight to the star of the relative velocity  $v_{dd}$  of detector and detector (the same instrument at different times or different instruments at the same time, *etc.*). The essential condition for a viable physical interpretation of stellar aberration is that only detector (not source) motion is involved.

### 3. Planetary Aberration

Planetary aberration is an effect of retarded propagation of light. It obeys the aberration formula, Equation (3), with  $v = v_{sd}$ . That is, planetary aberration increases with *source-detector relative velocity* (more exactly, with the component of such velocity transverse to the observer's line of sight—we sometimes omit this qualification for brevity). During the time interval in which light emitted by the source at position P is propagating to the detector, the source moves to some new position P', which it occupies at the instant of light detection (simultaneity being referred to the rest system K of the detector). Thus there may be a measurable angle between P and P' subtended at the detector. This is called an aberration angle, though other names might come to mind. (Eisner 1967 suggested angle of "light time lag"—other possibilities include "lead angle" of light aimed at the detector from the emitter, *etc.*). The same is true of the "aberration" of Penrose (1959) and Terrell (1959), which recycles the overworked  $\mathbf{e}$  of Equation (3), with  $v = v_{sd}$ , as an apparent turning angle of a relatively-moving three-dimensional solid, as viewed by a single point detector. We shall say nothing about that *cause célèbre*.

There are two ways of interpreting the angle  $\mathbf{e}$  of "planetary aberration," both of which partake somewhat of the metaphysical:

(1) It is the angle by which the direction (specified by angle  $\mathbf{a}$ ) from the detector to the pointlike light-source's position at the event of emission differs from the direction (specified by  $\mathbf{a}'$ ) from detector to the light-source's "present position" at detection time (time being measured in the inertial system K of the detector).

(2) It is the "angle of lead" by which photons, fired like bullets from the light source, must be aimed ahead of the "present position" of the relatively-moving point detector (at the event of emission, time being measured in the inertial system K' of the source) in order to intercept that detector at a later time.

Both interpretations assume linear extrapolations of positions—that is, true inertiality of the motions of K and K' during the entire interval of light propagation from emission to detection (absorption). Thus the concept of planetary aberration is physically useful primarily for rather short propagation times and limited source-detector distances. The linearity assumption breaks down completely for light sources at stellar distances. In fact the very concept of planetary aberration is useless for physics except in such cases (*e.g.*, planets) as acquire meaning and computability of "source trajectory" through the application of celestial mechanics. If initial conditions of source motion are unknown or unknowable, trajectories are not computable and *position of the light source at detection time or of the detector at emission time* is an operationally meaningless concept. Moreover, it is not a relativistically invariant concept, since it depends on distant simultaneity in one inertial system or the other.

Is there any invariant way of formulating the physical definition of planetary aberration? Mathematically, this may be accomplished without difficulty by combining the symbols descriptive of aberration with those descriptive of Doppler effect to form a 4-vector. But this evades the question of *physical* definition . . . and we shall see presently that any "fading to mere shadows" of the difference between two operationally quite distinct physical phenomena creates another problem, which will be left as a puzzle for the interested reader. Along with it we offer the following thought questions: Do astronomers really need the noninvariant concept of planetary aberration? Of what use is it to them to quantify where a distant planet or the Sun is at the *present instant*?

Unfortunately, it would seem that one cannot give the quick and easy negative "relativistic" answers that spring to mind . . . for in fact celestial mechanics, very accurately governed on the scale of the solar system by Newton's instantly-acting gravity, would appear to have good practical uses, *e.g.*, for the concept of "present position of the Sun." In fact, it may be hard to get along without it (since the present position of the Sun is what our planet mainly depends on to guide its orbital progress from moment to moment), and one rather hopes for the sake of future astronauts that astronomical science will, at whatever ideological cost, avoid trying to do so. (Note that there is no such known phenomenon as *gravitational* aberration—although for a century people such as Jefimenko (1994) have persisted in trying to fly in the face of this fact by representing gravity as retarded in its force action—and for

that very reason it is important to correct intra-solar-system observations for *optical* aberrations.)

#### 4. Stellar Aberration

Stellar aberration in its physical interpretive aspects is by a wide margin the subtlest scientific subject ever encountered by this writer. New ideas about it seem to arise almost daily. This paper has been rewritten half a dozen times, and each time it has looked completely different. The reader will have to bear with the present report as a fallible one of tentative progress to date.

To gain a notion of the physical aspect of stellar aberration, consider the sketch in Figure 1. Inertial system K comoves with our earthly telescope, designated #1. We arbitrarily take our light source to be a star at the zenith ( $\mathbf{a} = \mathbf{p} / 2$ ). We suppose that the star is in fact at rest in another inertial system K' moving with speed  $v_{sd}$  relatively to K. If in the vicinity of the earth (for instance, borne by an earth satellite) we have a second telescope, designated #2, at rest in K', then that telescope must be tilted at a different angle  $\mathbf{a}'$  such as to have a more "forward" inclination in the direction of  $\mathbf{v}_{sd}$ , if it is to intercept photons comoving with those detectable on earth (*i.e.*, part of the same "ray"). The vertical downward photon propagation direction in K is denoted by unit vector  $\hat{\mathbf{n}}$ , the downward-slanted direction in K' by  $\hat{\mathbf{n}}'$ . (If  $\hat{\mathbf{m}}$  is a unit vector in the direction of  $\mathbf{v}_{sd}$ , then  $\hat{\mathbf{m}} \cdot \hat{\mathbf{n}} = -\cos \mathbf{a}$ ,  $\hat{\mathbf{m}} \cdot \hat{\mathbf{n}}' = -\cos \mathbf{a}'$ .)

An important observation made by Marmet (1994), and noted by others, is that in K (where the source moves with speed  $v_{sd}$ ) the path of the ray entering telescope #1 (negative of the apparent direction to the star) is *fixed*. The photons have to come straight down from the zenith in K, regardless of source motions. This means that in K' what we have marked as "downward ray" will not enter telescope #2, nor will it be the same ray that enters #1. The latter is instead the ray marked  $\hat{\mathbf{n}}'$ , inclined at angle  $\mathbf{a}'$  in K'. At first order we see from simple Galilean kinematics that, in order to meet the condition of verticality in K,  $\hat{\mathbf{a}}'$  must deviate from verticality in K' by a "backward" or "over the shoulder" velocity component equal to  $-\mathbf{v}_{sd}$ , just sufficient to *cancel* the effect of "forward" motion of K' with respect to K. [At higher orders the relativistic velocity composition law must replace the Galilean one, with the same consequence of cancellation.] But this cancellation condition, needed to ensure a fixed, rigorously vertical ray in K, applies independently of the magnitude of  $v_{sd}$ , given an omnidirectional source. In consequence, the parameter  $v_{sd}$  drops out of the discussion . . . so *source speed plays no role in the description of stellar aberration*—in agreement with the nature of stellar aberration, known empirically since its discovery by Bradley.

Thus an analysis of stellar aberration in terms of *source-detector relative velocity*—just as needed to describe planetary aberration—nevertheless leads to elimination of the pa-

rameter  $v_{sd}$  from description of the phenomenon. In effect stellar aberration can be viewed as a limiting form of planetary aberration, wherein both types share analysis in terms of source-detector relative motion. We have repeatedly emphasized in the mathematical analysis, and shown in our formulas, a duality or reciprocity between K and K', such that, by a simple swap of descriptors and change of sign of relative velocity, the two systems are completely interchangeable. There is also, as we know, a reciprocity of Maxwell's equations, having to do with their invariance under time reversal, whereby the source and detector functions (emission and absorption of radiation) can be interchanged without altering the ray path. In a moment we shall make use of this fact.

So far we have shown only that in inertial system K what will be observed is unaffected by stellar proper velocities. But as long as K remains strictly inertial no aberration of stars will be observable in any case. The star image in Figure 1 must just sit forever at the zenith as viewed in telescope #1. This is a well-known property of true inertial systems, but it tells us nothing about the observable phenomenon of stellar aberration.

To make a quantitatively correct prediction of stellar aberration employing the first-order formula derived above, *viz.*,  $\mathbf{e} = \mathbf{a} - \mathbf{a}' = (v/c) \sin \mathbf{a}$  (radians), it is necessary to interpret  $v$  in this formula as relative speed of the *detector* in two different states of motion. [To emphasize this we may write  $v$  in the formula as  $v_{orb}$ , denoting mean orbital speed of the Earth or detector (telescope).] This has been recognized by some authors such as Sygne (1965) and not by numerous others such as Møller (1972). The formalism gives of course no hint of how this parametric switch from  $v_{sd}$  to  $v_{orb}$  occurs. Let us assemble what we have learned so far and see if we have enough logical ingredients to provide clues to this mystery. First, consider the situation portrayed in Figure 1.

(A) For source motion arbitrary, detector motion inertial:

- $\mathbf{a}$  in K retains a fixed, constant value.
- $\mathbf{a}'$  in K' adjusts itself automatically to cancel all effects of source motion on detector aiming.

[The automaticity here has nothing to do with cybernetics or precognition. It amounts to ray selection from an omnidirectional source.] Now let us assert Maxwellian reciprocity of source and detector—with the ray reversing its direction, while the telescopic *detector* (now in thought acting as ray emitter) stays on earth in K and the stellar *source* (now acting as absorber) stays at rest in K'—to hypothesize:

(B) For detector motion arbitrary, source motion inertial:

- $\mathbf{a}'$  in K' retains a fixed, constant value.
- $\mathbf{a}$  in K adjusts itself automatically to cancel all effects of detector motion on source aiming.

[By *source aiming* we mean selection of a direction, from an omnidirectional stellar source in  $K'$ , coincident with a ray capable of being detected in  $K$ .] From these hypotheses, assumed valid, we make a final extrapolation to the general case:

- (C) For arbitrary motions of both source and detector:
- $\mathbf{a}$  in  $K$  adjusts itself automatically to cancel all effects of detector motion on source aiming.
  - $\mathbf{a}'$  in  $K'$  adjusts itself automatically to cancel all effects of source motion on detector aiming.

Item (A) is simply a summary of empirically known facts about stellar aberration. Item (B) is pure speculation in need of observational confirmation (see below). Item (C) is also speculative, but plausible if (B) is correct. Supposing that (C) is correct, we remark that despite all the “automatic cancellation” hypothesized there remains an *effect of detector motion on detector aiming* and an *effect of source motion on source aiming*. The former is well known; the latter must remain speculative, since we have no control over stellar source motions and cannot very easily experiment. The most pressing need is to verify or refute item (B). This we consider in the next section.

## 5. Observational Testing

Do the present considerations lend themselves to observational testing? Yes, hypothesis (B) above is speculative but can probably be tested rather readily. A common way to test an hypothesis is to assume its opposite and look for a contradiction of fact or observation. Item (B) says that for a star in inertial motion and our earthly telescope in arbitrary noninertial motion (a requirement satisfied by its actual orbital motion)  $\mathbf{a}'$ , the angle of emission of the ray seen by our telescope, will remain fixed regardless of our detector motions. This is a very counter-intuitive mo-

tion. Much more intuitive is its contradiction, the “duck-hunter” model often used in explaining aberration:

**Duck-hunter Model:** *The hunter’s gunbarrel (source emission ray-path) has to be aimed to compensate not only for uniform relative velocity of the duck (detector, telescope) and gun but also for any noninertial maneuverings of the duck.*

Our item (B) boldly contradicts this and thus stands in need of observational testing. The most obvious conception, based on the duck-hunter model, asserts that the source directs its earth-detectable rays backwards “over its shoulder” at just such a (variable) angle  $\mathbf{a}'$  as to cancel (compensate) the effect of any *source-detector relative velocity* component transverse to line-of-sight. Thus  $\mathbf{a}'$  varies with detector proper motions. This can almost surely be tested.

Since we know in any case that nobody aboard a star is aiming a searchlight in such a clever way as to compensate variations in  $v_{sd}$ , it is apparent that most stars are visible to us only because of the (approximate) omnidirectionality of their light emissions. Testing of the duck-hunter model [counter-hypothesis to (B)] should be feasible if stellar sources can be found that emit their omnidirectional light *not uniformly* but, *e.g.*, in a high-intensity “beam” directed almost toward us . . . or more generally if there exist stellar light sources having strong local departures from directional homogeneity of light emission on a scale of angular variation comparable with (not vastly greater than) the 20 arc-seconds of stellar aberration due to earth motion.

In the case of a beam, if its “pointing” is a stable aspect of the relative geometry (*i.e.*, if the searchlight is fixed in space, not variably “aimed”), so that the beam points in a constant direction or in a direction that varies on a time scale long compared with the earthly year, then we should observe with any changes of either source velocity or detector velocity a modulation of light intensity having a pe-

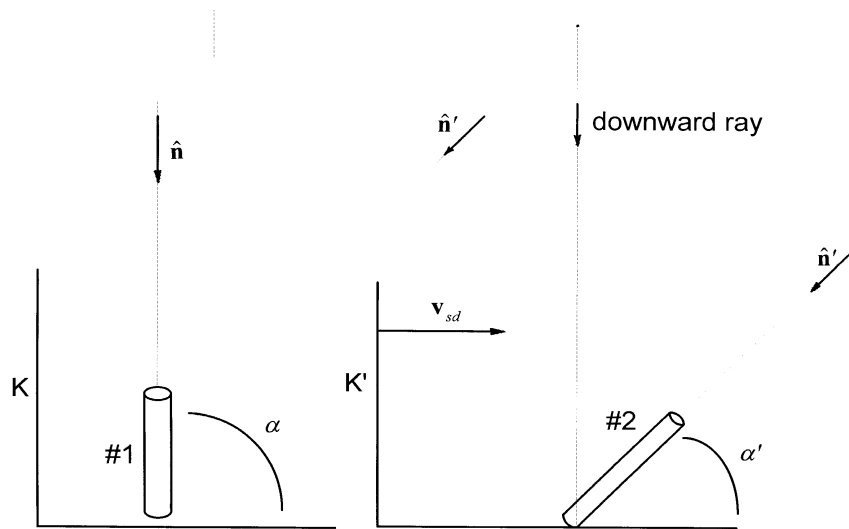

**Figure 1.** Stellar aberration in terms of source-detector relative velocity  $\mathbf{v}_{sd}$ . Telescope #1 at rest in earth inertial system  $K$ , star at zenith. Telescope #2 and source at rest in  $K'$  (telescope distant from source). Horizontal component of  $\hat{\mathbf{n}}'$  compensates  $\mathbf{v}_{sd}$ .

riod of one year for the detector motions and whatever other period (if any) may govern source motions. To repeat: *Intensity modulations* of one-year period must arise unavoidably, according to the duck-hunter model, if the light beam directed toward us is sharply directional. These modulations reflect annual variations in the direction of  $\hat{n}'$  or value of  $\alpha'$ , the emission angle (determined in the geometry of Figure 2 by  $-\hat{n}' \cdot \mathbf{v}_{sd} = v_{sd} \cos \alpha'$ ) needed to intercept the earth in its annual motions. Figure 2 illustrates. These directional variations, as we have said, are implied by the duck-hunter model and are denied by our hypothesis (B).

Since a popular “relativistic” way of explaining observed apparent superluminal motions of sharply-beamed astronomical “jets” is that these are directed *very nearly toward us*, the present considerations provide a double-barreled way of checking the consistency of theory: The light from such nearly earth-pointing jets should exhibit annual *intensity* changes additional to and unconnected with the normal annual  $20.5''$  *direction* aberrational changes, if (B) is wrong. This is the case because, as the earth orbits, our telescope intercepts the light emitted from the source at slightly different emission angles  $\alpha'$ —off-angles of the jet. If (B) is right, no such intensity changes of annual period are to be expected.

In effect, according to the duck-hunter model, as sketched in Figure 2, the emitted photons have to be “aimed” at us differently at different times of year in order to enter our telescope, because we are a maneuvering target. (Note that this effect, if it exists, is strictly a result of our earth’s *velocity* changes—it has nothing to do with parallax due to orbit diameter.) If no such annually periodic intensity modulations of “apparently superluminal” sources are observed, this will constitute presumptive evidence in favor of our hypothesis (B). Should annual intensity modulations of any stellar light sources be observed, this will work in favor of the duck-hunter model and necessitate retreat from the view of stellar aberration here advocated.

According to the hypothesis (B) viewpoint, what is wrong with the duck-hunter model? Nothing at all, to be sure, if the detector were either a normal duck or a mathematical point. But this is a duck with a difference, a duck with complications. It is an armored duck that can be killed only with a shot to the gullet, straight down its long, tubular neck. It is also a singularly stupid or suicidal duck, for although it is adept at dodging, with every change of its velocity there is a correlated change of tilt of its tubular neck. The rule is, according to (B), that the correlation brings about precisely the tilt-angle change needed to cancel the effect of the velocity change, so that a fixed aiming direction on the part of the hunter suffices.

Thus our detector (telescope) is known to tilt annually in correlation with its own noninertial motions, and by the (B) view this tilting also effects a counter-compensation of the gun aimings at the source end de-

signed to compensate for the duck’s dodgings—the result being that the aiming angle  $\alpha'$  at the source end is unaffected by variable detector motions, just as the receiving angle  $\alpha$  at the detector end is unaffected by variable source motions. If that is a trifle *raffiniert*, note that you were warned.

## 6. Summary

We have arrived at item (C), above, which encapsulates our findings concerning the physical nature of stellar aberration, on the basis of assumptions compatible with special relativity theory. That is, our analysis has employed as its sole velocity parameter the *source-detector relative velocity*  $v_{sd}$  between inertial systems K, K', just as Einstein did in 1905. The other major ingredient in our reasonings—the assumption of reciprocity or dualism between source and detector, accompanying ray-direction reversal—is also compatible with relativity and with a Maxwellian description of light.

So, the present analysis and the morning stars all sing together in celestial harmony with the known eternal verities of physics, right? Any AIP journal would welcome our submission, right? Wrong and wrong. There’s still plenty that needs greasing among the squeaky joints that connect relativity ideology to the real world. For instance, we have not shown any mathematical path between the  $v_{sd}$  and  $v_{orb}$  parametrizations. Consider the following two-paragraph essay entitled, “Where covariance fails:”

The Lorentz transformation of the  $k_m$  four-vector of light propagation is parametrized by the relative velocity  $v$

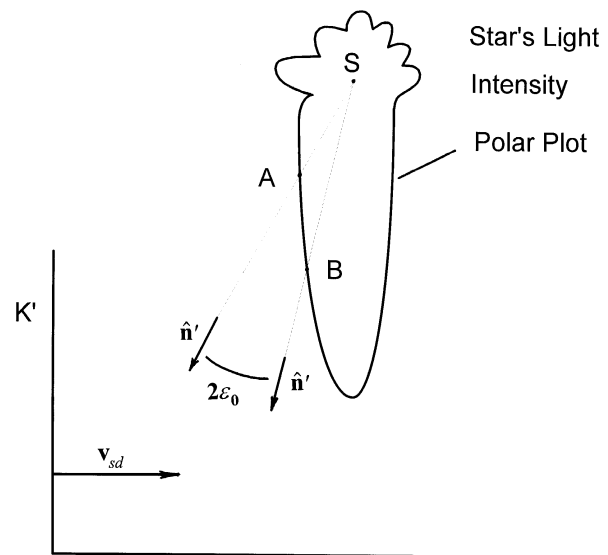

**Figure 2.** Duck-hunter model, showing effect of “beaming” of starlight. At any six-month interval the two emission directions  $\hat{n}'$  in K', produced by orbital detector motions affecting  $\mathbf{v}_{sd}$ , are separated by an angle equal to twice the constant of aberration,  $\epsilon_0 = 20.5''$ . The light intensities in these two directions are in the ratio of lengths SA:SB. Annual modulation of the light intensity detected by an earthly detector results.

of two inertial systems,  $K, K'$ . That transformation, expressing the components of  $k_m'$  in terms of those of  $k_m$ , describes both the Doppler effect on frequency and some kind of optical aberration, purported to be stellar. (In fact we have shown that there is some substance in that claim.) The inextricably combined description of these two physical phenomena, Doppler and aberration, reflects the fact that they are physically symmetrical in exactly the same way that “space” and “time” are physically symmetrical—this being the *meaning of covariance*. Just as no correct physicist can fail to speak of *spacetime*, and as our equally politically aware Air Force brethren-in-propaganda take care to speak of *aerospace*, we must twist up our forked tongues and speak of “*Dopplerstellaraberration*,” *all distinction being faded to mere shadows*. (This elocution will occur in unison, commencing at 9 AM Monday, by Deans’ orders posted on all bulletin boards.)

The Doppler effect depends for its quantitative description on the source-detector relative velocity parameter  $v_{sd}$ . Since there is one and only one  $v$ -parameter involved in the Lorentz transformation, it follows by necessity that  $v = v_{sd}$ . Stellar aberration depends for its quantitative description on the earth’s orbital velocity  $v_{orb}$ . Hence by equally stringent necessity  $v = v_{orb}$ . But in general  $v_{sd} \neq v_{orb}$ . Hence  $v \neq v$ , a relationship that should trouble relativists, since it would trouble the mathematicians from whom as a class they are indistinguishable by operational test.

We call attention to the need for some astronomical data-gathering, or examination of existing data, in order to determine if any examples exist of stellar objects with known directional inhomogeneities of radiation emission (particularly “relativistic jets”) that display intensity variation periods exactly equal to one year. If this proves to be a prevalent condition—or even if enough examples can be found to exceed pure statistical chance—then our hypothesis (B), above, is empirically counter-indicated, the simple “duck-hunter model” is supported, and the present attempt to clarify the underlying physics of stellar aberration will require agonizing reappraisal.

Finally, it might be mentioned that stellar aberration is by no means uniquely dependent for its quantitative description upon either Maxwell’s electrodynamics or Einstein’s relativity. Alternative theory (Phipps 1991) does exist, although present-day instrumentation does not support its crucial testing. In short, the mathematical part of the description [particularly the higher-order corrections in Equation (3)], which seems herein and to relativists so secure, is actually the part most vulnerable to change; whereas the physical or qualitative grasp of the situation, once achieved, is forever. Come, fellow physicists . . . surely something more to the point can be found than Eddington’s umbrella.

## References

- Aharoni, J., 1965, *The Special Theory of Relativity*, Oxford, 2nd edition, pp. 321-2.
- Einstein, A., 1905, *Annalen der Physik* 17:891.
- Eisner, E., 1967, Aberration of Light from Binary Stars—A Paradox?, *Am. J. Phys.* 35:817-819.
- Hayden, H.C., 1993, Stellar Aberration, *Galilean Electrodynamics* 4:89-92.
- Ives, H.E., 1950, *J. Optical Soc. Am.* 40:185 (footnote).
- Jefimenko, O., 1994, Gravitational Field of a Point Mass Moving with Uniform Linear or Circular Velocity, *Galilean Electrodynamics* 5:25-33.
- Marmet, P., 1994, Aberration of Light and Relative Motion, private communication.
- Møller, C., 1972, *The Theory of Relativity*, Oxford.
- Peirce, B.O. and Foster, R. M., 1957, *A Short Table of Integrals*, Fourth Edition, Ginn, p. 81, No. 617.
- Penrose, R., 1959, *Proc. Cambridge Philosophical Soc.* 35:137.
- Phipps, T.E., Jr., 1989, Relativity and Aberration, *Am. J. Phys.* 57:549-551.
- Phipps, T.E., Jr., 1991, Stellar aberration from the standpoint of the radiation convection hypothesis, *Physics Essays* 4:368-72.
- Sherwin, C.W., 1993, Two Types of Aberration, private communication
- Synge, J.L., 1965, *Relativity: The Special Theory*, North-Holland, pp. 146-8.
- Terrell, J., 1959, *Phys. Rev.* 116:1041.

